



Estonian Qualifications Framework EstQF and level 5

Heli Oruaas

12th of March, Tallinn



Estonian Qualifications Authority

- Private legal entity (foundation) **established 31.08.2001**
- **Founders:**
 - Estonian Chamber of Commerce and Industry
 - Estonian Confederation of Employers and Industry
 - Estonian Employees' Unions' Confederation
 - Confederation of Estonian Trade Unions
 - Ministry of Social Affairs
- Subordinated to **the Ministry of Education and Research**

Estonian Qualifications Authority

Functions

- Developing occupational qualifications system
 - Organising work of Professional Councils and working groups (developing occupational qualification standards)
 - Providing counselling and assistance for Awarding Bodies (awarding of occupational qualifications)
 - Maintaining state register of occupational qualifications
- Anticipating labor market needs (OSKA)
- Organising the work of National Europass Centre
- Estonian NCP for the EQF implementation
- EPALE centre in Estonia

Some general EstQF principles

- 8 levels which descriptors are identical to EQF level descriptors
- All different kind of qualifications will be placed into the framework

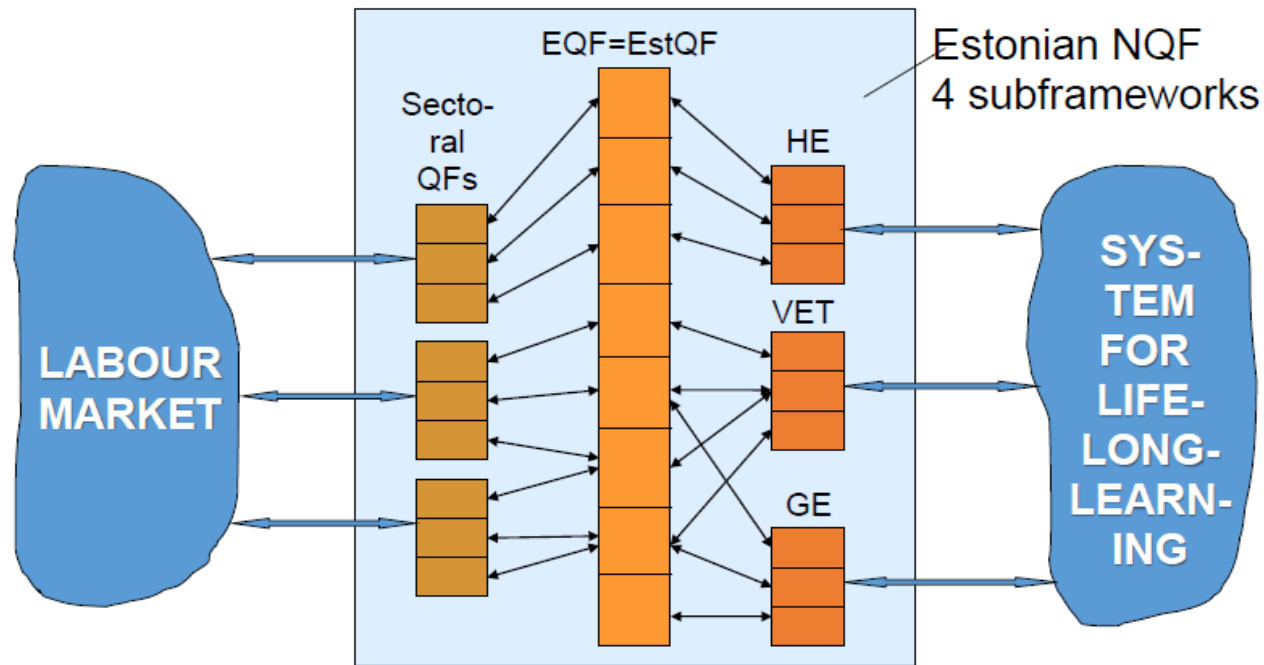

EstQF 4 subframeworks

- HE – higher education qualifications sub-framework (levels 6-8)
- VET – VET qualifications sub-framework (levels 2-5)
- GE – general education qualifications sub-framework (levels 1-2, 4)
- Sectoral qualifications frameworks comprise the occupational qualifications framework (levels 2-8)

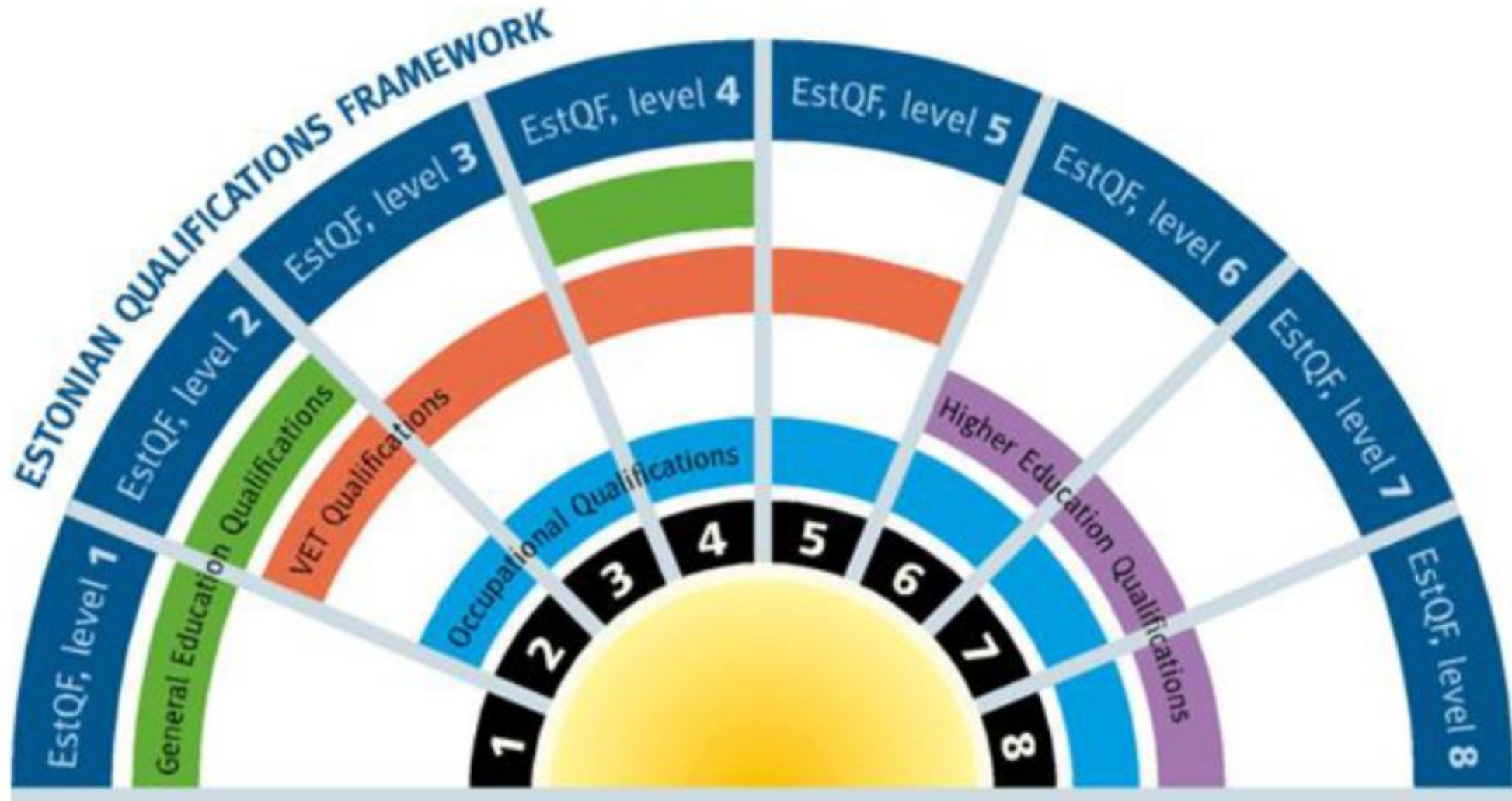

Placement of formal education qualifications and occupational qualifications in the EstQF

Formal education qualifications	EstQF levels	Examples of occupational qualifications
Basic education certificate based on curriculum for students with moderate and severe learning disabilities	1	-
Basic education certificate based on simplified curriculum Basic education certificate VET qualification certificate, level 2	2	Assistant gardener, Logger
VET qualification certificate, level 3	3	Electronic equipment assembler, Woodworking bench operator
Upper secondary general education certificate Upper secondary VET certificate VET qualification certificate, level 4	4	Harvester operator, Veterinary assistant
VET qualification certificate, level 5	5	Biogas plant operator, Mechatronic-technician
Diploma of Bachelor's degree, Diploma of professional higher education	6	Physiotherapist, Civil Engineer, Applied Architect
Diploma of Master's degree	7	Diploma engineer, Diploma architect
Diploma of Doctoral degree	8	Chartered civil engineer, Chartered architect

Brief history of level 5

Timeline	Formal education	Occupations
Till 1991 Soviet Union system	diploma of secondary specialized education (based on general secondary education)	Occupational levels 1-5 where 1 is highest and 5 is lowest level
Till 1999 Estonian National Qualifications	1) Diploma of secondary specialized education based on general secondary education; 2) Certificate of Secondary Specialized Education (based on general secondary Education)	-
Since 2001 Estonian Occupational Qualifications System	-	Estonian National Occupational Qualifications system, level I is lowest, level V is highest. Level II is recognised as a specialist level
Since 2008 EstQF	Levels 1-4 and 6-8	Levels 2-8, 5th level is recognised as a specialist level
2011 Referencing with EQF	Levels 1-4 and 6-8	Levels 2-8, 5th level is recognised as a specialist level
2016 New reference with EQF	Levels 1-8, level 5 recognised as a basic and continuous training in VET	Levels 2-8, 5th level is recognised as a specialist level

	Types of VET qualifications						
	Level 2 Basic training	Level 3 Basic training	Level 4			Level 5	
			Basic training		Continuous training	Basic training	Continuous training
Educational requirements for commencing studies	none	none	Vocational secondary education Basic education * Persons without basic education and at least 22 years of age	Basic education	Basic education plus competences required for level 4 qualifications	Secondary education	Upper secondary education plus the competences required for level 4 or 5 qualifications
Study volume in EstVETCP	15-120	15-120	180 <i>Exceptions expanding the study volumes will be stipulated in national curricula</i>	15-150 <i>Music and performance art curricula up to 180</i>	15-60	120-150 <i>Military and internal security curricula ranging between 60-150</i>	15-60
Ratio of practical assignments	at least 70%	at least 50%	at least 35%	at least 50%	at least 50%	at least 50%	at least 50%
Opportunities for further study	Obtaining basic education * If basic education has been acquired, general secondary education or vocational secondary education or entry level 4 vocational training * Persons without basic education and at least 22 years of age Vocational secondary education * Level 3 vocational training	Obtaining basic education * If basic education has been acquired, general secondary education or vocational secondary education or entry level 4 vocational training * Persons without basic education and at least 22 years of age Vocational secondary education	Level 4 or 5 vocational education continuing training * General education studies lasting 1 year * Vocational higher education or bachelors studies	Level 4 vocational education continuing training * General or vocational secondary education * If secondary education has been acquired – level 5 vocational training or vocational higher education or bachelor studies	General or vocational secondary education * If secondary education has been acquired – level 5 vocational training or vocational higher education or bachelor studies	Level 5 vocational education continuing training * Vocational higher education or bachelors studies	Vocational higher education or bachelors studies
Corresponding labour market requirement	Manual labourers	Simpler professions involving operating machines and devices, less complex skilled labourers, craftsmen and sales/service personnel	More demanding tasks involving machines and devices, craftsmanship and skilled labour, skilled labourers in the fields of agriculture and fishing, service and administration			Intermediate level specialists, technicians and officials	Complex tasks involving machines and devices, craftsmanship and skilled labour, highly skilled labourers in the fields of agriculture and fishing, service and administration

Thank You!

ncp@kutsekoda.ee

www.kutsekoda.ee

+372 679 1714

